

JOB NAME _____

Type _____

CATALOG NUMBER _____

Downlites

Square Concrete Mount

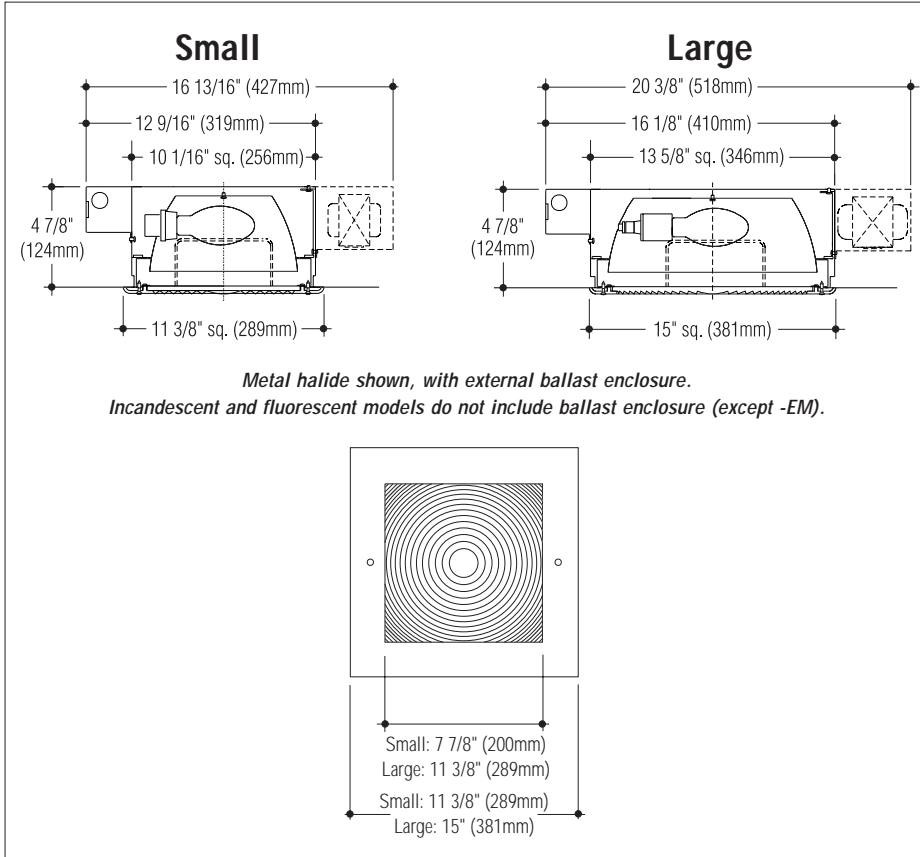

Specifications

Construction

- Cast aluminum trim with metallic aluminum polyester coating. Other colors are available.
- 16 gauge steel housing with white polyester coating
- Drop-hinged trim secured by two stainless steel captive screws
- Semi-specular aluminum reflector
- Flat fresnel glass lens standard for incandescent and metal halide models; flat Pattern 73 prismatic glass lens for fluorescent models. Other shielding is available.

Electrical

- Fixture is wired for a single, horizontal lamp of varying types and wattages
- Fluorescent ballasts are electronic 120V-277V (347V optional)
- Metal halide ballasts are core and coil 120V/277V (347V optional). Electronic ballast optional.
- Integral junction box has 1/2" conduit knockouts at each end and two in back
- Junction box is accessible from above for conduit installation before concrete pour, and accessible from within housing for wiring after the fixtures is embedded in place.
- ETL/cETL listed for concrete mounting

Mounting

- Housing has flanges for attachment to forms.

How to Specify

1. Select catalog number.
2. Add suffixes for options required to meet job conditions.

	Catalog Number	Wattage/Lamp	Base
Small	<input type="checkbox"/> 2408	32W triple 4-pin fluorescent	GX24q-3
	<input type="checkbox"/> 2508	100W metal halide	E17 Medium
	<input type="checkbox"/> 2608	150W incandescent	A21 Medium
Large	<input type="checkbox"/> 2412	42W triple 4-pin fluorescent	GX24q-4
	<input type="checkbox"/> 2512	150W metal halide	E17 Medium
	<input type="checkbox"/> 2612	200W incandescent	A21 Medium

Options

Trim:

Satin Stainless Steel. Add suffix -N.

Cast Guard. Add suffix -G.

Cast Regressed. Add suffix -P.

Shielding:

Drop Lens (Large only) Holophane #771. Add suffix -771. Flat 3/8" Tempered Frosted Glass.

Add suffix -HD.

Emergency Battery: Provides 90 minutes operation. (Fluorescent only) Add suffix -EM.

Weatherproof Gasket: Add suffix -W.

Tamperproof Screws: Add suffix -TP. **Ballasts:** 277V, 347V. Add suffix -277, -347.

Electronic HID: Add suffix -EB.

Alternate Faceplate Color: Black and White.

Add suffix -BLK or -WHT.



C. W. Cole & Company, Inc.
2560 N. Rosemead Boulevard
South El Monte, CA 91733-1593

Fax (626) 443-9253

Tel. (626) 443-2473

info@colelighting.com

www.colelighting.com